

## nelesACE™ BASIS WEIGHT CONTROL VALVE

Basis weight control is one of the most critical applications for a valve in a paper machine. Metso nelesACE is the ultimate offering for this application. The unit consists of a reliable V-port segment valve, complete with a high-resolution step-motor-driven rotary actuator, limit switches, and potentiometer. nelesACE control unit's unique feature to run valve with various step sizes, depending on error between actual and desired flow rate, makes it a superior element for basis weight control. Any error can be eliminated quickly and accurately without overshooting. This helps e.g. reduce settling time during grade change.

The valve, Metso R Series V-port segment valve, is available in sizes DN 50 - 250 / 2" - 10" in a flangeless design, and DN 50 - 500 / 2" - 20" in a flanged design. Complete valve specifications, dimensions, and material of construction details are available in bulletin 3 R 21 and 3 R 24.

The electro-mechanical actuator uses a bipolar stepping motor to accomplish discrete and repeatable angular movement of each step. There is only one size actuator to suit the full range of valves offered. Valve position is clearly indicated by a feedback potentiometer that transmits an electrical signal to the display at the control unit. Mechanical limit switches are used to prevent over travel. A handwheel is provided for manual operation.

### FEATURES

#### System compatibility

- The nelesACE is compatible with virtually all leading QCSs.

#### Rugged, economical V-port segment valve

- High rangeability
- Equal percentage flow characteristics
- Solid-metal seat and maintenance-free bearing and packing provide long service life.
- Valve stem is pinned and welded to the segment and the valve seat is welded away from the segment to reduce hysteresis.
- Rugged one-piece body
- PTFE stem bearings and the trunnion mounting of the segment reduce operating torque.

#### Step-motor-driven actuator

- Step-motor-driven backlash-free rotary actuator provides the extreme accuracy needed in basis weight control.
- Performs precise, minimal changes in valve position with high repeatability and resolution.
- Assures consistent paper grade quality.



#### High resolution conformance

- Measurement devices today are capable of sensing a  $\pm 0.1\%$  change in weight. Metso Nelprof® control valve sizing program can easily calculate proper valve size and degree of opening to provide basis weight control valve with precise accuracy.

#### Flexibility to operate on a variety of inputs

- Simple wiring determines whether the nelesACE responds to a pulse duration or a time duration.

#### Allows remote electronic control

- Electronic controls can be located up to 120 meters / 360 feet away, but in a normal operation the nelesACE control unit is installed near the valve. Standard cable length is 20 m.

#### Feedback potentiometer

- Standard 1 kOhm potentiometer gives  $\pm 0.25\%$  linearity feedback (0.0025% of span). Output signal of control unit is 4-20 mA signal.

#### Limit switches

- End-of-travel limit switches are standard to prevent the valve from over-traveling.

#### Position indication

- Located on the cover of the actuator, the potentiometer/limit switch housing also incorporates a valve position indicator.

#### Manual override

- A handwheel at the end of the motor allows for manual operation in the event of loss of power with minimum effort and a minimum number of turns.

## OPERATING PRINCIPLE

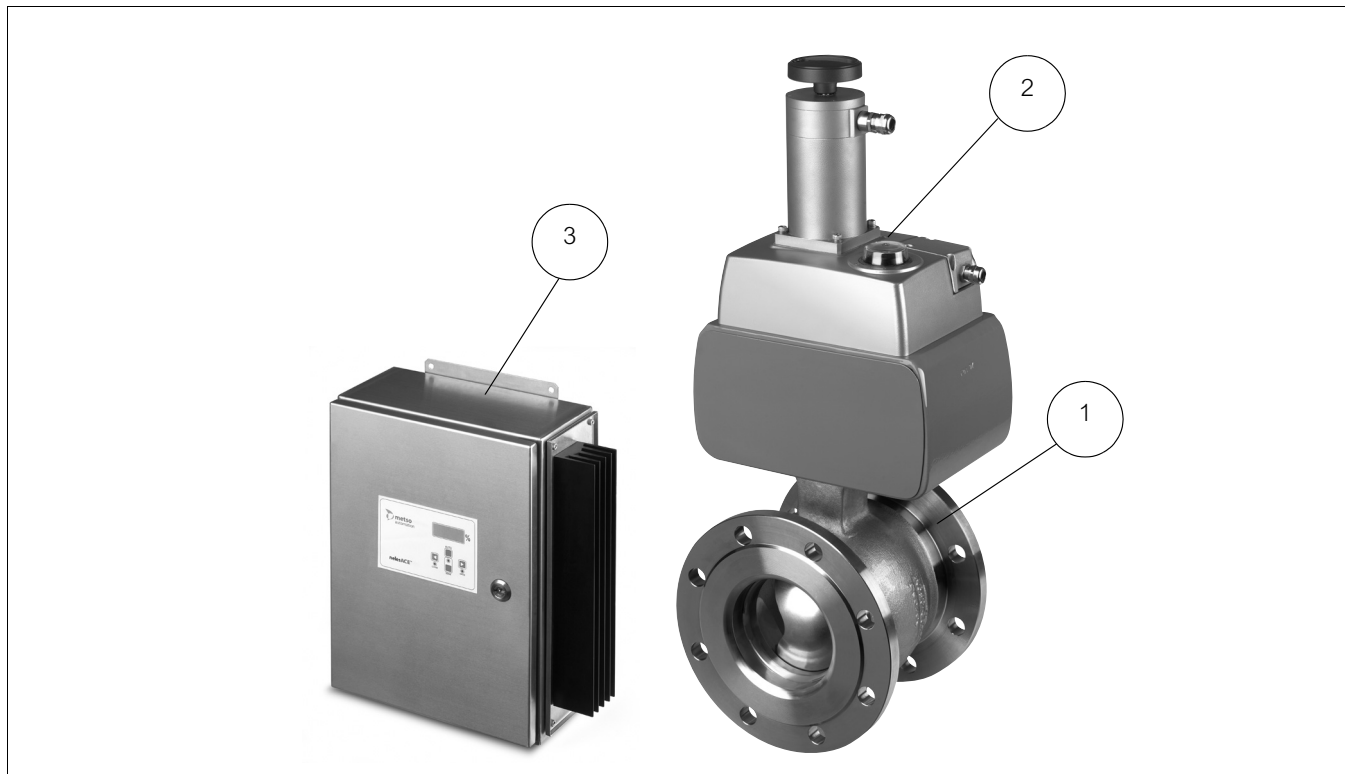

### 1. The valve

The nelesACE basis weight control valve is based on our standard R Series V-port segment control valve familiar from many other paper mill applications.

Metso RA / RE V-port segment valve has numerous applications in demanding processes where high rangeability and equal percentage flow characteristics are needed. It's solid metal seat and maintenance free bearing and gland packing guarantee long service life. The rugged, one piece body withstands great mechanical force and, together with the PTFE stem bearings and the trunnion mounting of the segment, the operating torque is reduced to a minimum.

High rangeability makes the RA / RE valve optimal to paper machines where production adjustments alter flow rates significantly.

For complete information, please see Metso bulletin 3 R 21 and 3 R 24.

### 2. The actuator

The extreme accuracy needed in basis weight control is achieved by a step-motor driven, backlash-free rotary actuator. It performs precise, minimal changes in valve opening with high repeatability and resolution. The rotary actuator is electromechanical.

One size of actuator covers all the requirements for whole range of valve sizes. A bipolar stepping motor is used to accomplish a discrete and a repeatable angular movement out of each step.

The shaft can also be manually operated with a handwheel attached to the end of the motor. The inbuilt mechanical limits are used to prevent the overtravel. The valve position is clearly indicated at the cover of the actuator and a feedback potentiometer transmits a signal to the display at the control station or for customer use.

### 3. The control unit

When it's time to change grades and set a new basis weight, the control unit and the actuator quickly turns the valve to a new opening range with minimal downtime.

Equipped with pulse train and time duration interface, nelesACE is compatible with any process computer output. The control unit operates in a response to a control command from a computer or an electronic controller. As a standard feature there is also a push-buttons for manual operation (open and close) and a digital position display.

The DCS operation is activated in the "automatic" mode as a standard. Analog output (4–20 mA) can be used in the DCS to indicate valve position. In the manual mode the control unit replaces the signals of the computer and the valve can be operated manually from the push-buttons of the control unit. The push-buttons are lit during operation. In-built potential-free outputs will inform the DCS of the state and mode of the control unit.

### TECHNICAL SPECIFICATION

#### V-port segment valve, type RA / RE

Construction: Flangeless or flanged V-port segment valve.  
 Nominal dimensions: DN 50 - 500 / 2" - 20".  
 PN 25/40 (ANSI 150/300).  
 Flow coefficients Cv: 180 - 8510 (100% open).  
 Standard materials: Body: ASTM A 351 gr. CF8M  
 Segment: AISI 329 (SS 14 2324)  
 Shaft&pins: AISI 329 (SS 14 2324)  
 Seat: Cobalt based alloy

Standard temperature range: -40...+260 °C / -40...+500 °F.  
 Operation range: 90 degree;  
 With full steps: 7050 step / 90°  
 With half steps: 14100 step / 90°

#### Flow coefficients (Cv)

Valve Size mm / inches	Cv 100% open	Valve Size mm / inches	Cv 100% open
50 / 2	180	200 / 8	2030
65 / 2.5	280	250 / 10	3210
80 / 3	420	300 / 12	4490
100 / 4	620	350 / 14	6440
150 / 6	1260	400 / 16	8510
		500 / 20	13015

#### Step motor rotary actuator

Valve sizes: DN 50 - 500 / 2" - 20"  
 Output torque: 30 - 450 Nm, adjustable  
 Gear ratio: 1:141  
 Resolution per step size: 2 steps 3525  
 1 step 7050  
 1/2 step 14100 (default)  
 1/4 step 28200  
 Speed of operation: 7 to 3000 sec., adjustable  
 (90 degree rotation)  
 Manual handwheel turns: 35  
 Limit switches: 2  
 Feedback potentiometer: 1 kOhm

#### VALVE SIZING

Example  
 Basis weight measurement devices today are able to sense changes of ±0.2%. Paper machine data necessary to position a valve include: production rate, basis weight, wire size, machine speed, stock consistency, feed line, pressure drop and of course paper grade. Metso Nelprof® program can provide accurate sizing to determine the best valve size for the application.

In the following example, an DN200 / 8-inch R Series valve was selected. Case 1 gives the position of the valve under a given set of process conditions. Case 2 and 3 yield the resulting change in flow rate by altering the valve opening position: 1 step for Case 2 and 1/2 step for Case 3. It is interesting to note that the nelesACE has the capability to control to ±0.014% about the set point using full steps (pulses) and ±0.007% using 1/2 steps.

Number of steps/round: 200  
 Step angle: 1,8° in full step mode  
 Compatible with the ministep mode  
 Protection class: IP68 and NEMA4 for step motor, IP65 and NEMA4 for gear housing  
 EMC and CE approved  
 (EN 60034-1)  
 Holding torque: 5,4 Nm  
 Insulation class: F  
 Max. ambient temperature: +50°C

#### Control Unit

Supply voltage: 230VAC, option 115VAC  
 45...65 Hz  
 Nominal power: 200W max., motor power  
 Output power: Max. 9A, 70 VDC to motor in 6,3 A  
 Protection class: IP65  
 EMC and CE approved  
 Max. ambient temperature: 50°C  
 Connections: Screw terminals  
 Control Signals: 24 VDC  
 Inputs are galvanically isolated. Additional input for selection of step modes and speeds.  
 Pulse duration: Min input freq. 0 Hz  
 Max input freq. 400 Hz (1/4, 1/2, 1/1-step)  
 200 Hz (2/1-step)  
 Time duration: Default speed 150 Hz  
 Min. speed 50 Hz  
 Max. speed 2 kHz  
 Frequency response in manual mode: 5 Hz to 2 kHz  
 (default 200 Hz)  
 Electronics location: Max distance between motor and electronics is 120 m. / 360 ft.  
 Manual push-button: man/auto push buttons  
 open / close push buttons  
 LCD display

#### Process data

Pipe	DN 250 / 10.00"		
inlet diameter	DN 250 / 10.00" schedule no. 10		
outlet diameter	DN 250 / 10.00" schedule no. 10		
Fluid	Pulp Mechanical pulp 2 / 80 220 bar / 3208.20 psi		
Case no.	1.	2.	3.
Flow rate (gpm)	800.00	800.88	800.44
Upstream temp. (°C/°F)	50/120.00	50/120.00	50/120.00
pressure (bar/psi)	1.80/25.500	1.80/25.500	1.80/25.500
vap. press. (bar/psi)	0.116/1.693	0.116/1.693	0.116/1.693
Differential pressure (bar/psi)	0.345/5.000	0.345/5.000	0.345/5.000

#### Calculated performance

Case no.	1.	2.	3.
Capacity (FpCv)	374.97	375.39	375.18
Percent of full travel	56.76	56.79	56.77
Opening in degrees	56.51	56.54	56.53
Sound pressure level (dBA)	51.7	51.7	51.7
Flow velocity—inlet (m/s/ft/s)	1.53/5.106	1.56/5.112	1.55/5.109
Terminal press. drop (bar/psi)	1.23/17.85	1.23/17.85	1.23/17.85

**DIMENSIONS**

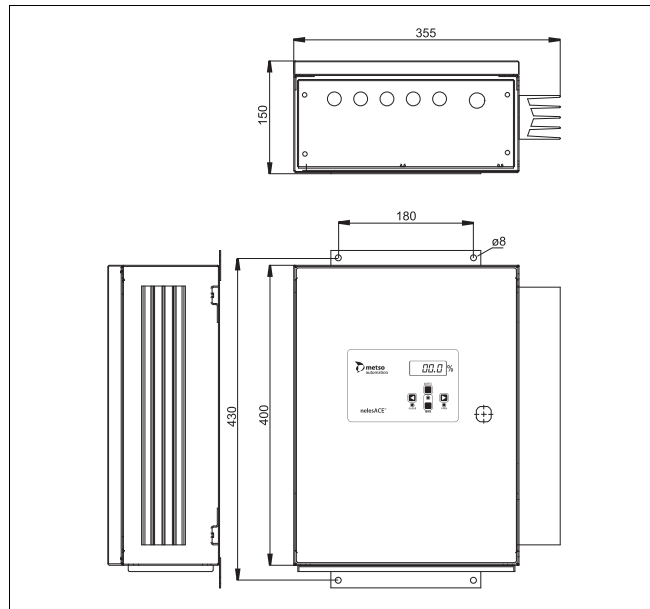
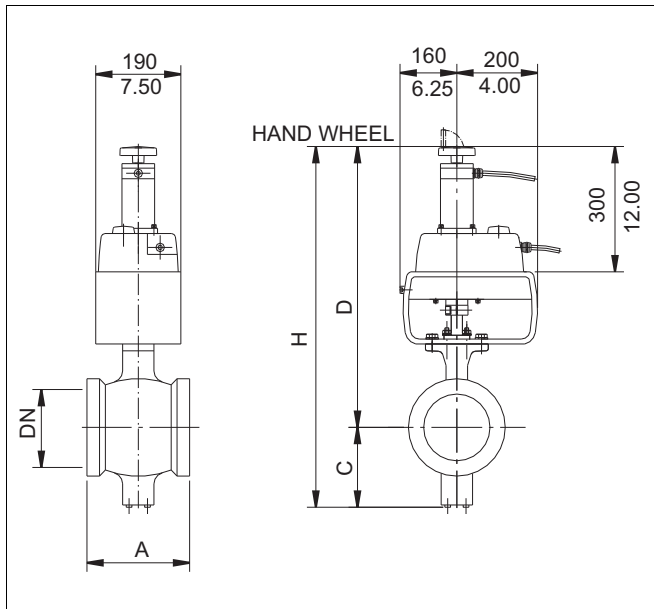

DN	Dimensions, mm										Weight, kg	
	Actuator	RA				Actuator	RE				RA	RE
		A	C	D	H		A	C	D	H		
50	NC4L-50	75	95	530	625	NC4M-50	124	91	<b>610</b>	<b>705</b>	35	40
65	NC4L-65	75	100	540	640	NC4M-65	145	97	<b>615</b>	<b>715</b>	38	42
80	NC4L-80	100	110	555	665	NC4M-80	165	108	<b>645</b>	<b>755</b>	40	45
100	NC4L-100	115	120	565	685	NC4M-100	194	120	<b>655</b>	<b>775</b>	42	50
150	NC4L-150	160	175	610	785	NC4M-150	229	174	<b>700</b>	<b>875</b>	59	72
200	NC4L-200	200	200	645	845	NC4M-200	243	201	<b>755</b>	<b>960</b>	83	131
250	NC4L-250	240	250	720	970	NC4M-250	297	251	<b>830</b>	<b>1085</b>	115	156
300	NC4L-300	-	-	-	-	NC4M-300	338	269	<b>855</b>	<b>1125</b>	-	220
350	NC4L-350	-	-	-	-	NC4M-350	400	311	<b>950</b>	<b>1265</b>	-	300
400	NC4L-400	-	-	-	-	NC4M-400	400	353	<b>1015</b>	<b>1370</b>	-	380
500	NC4L-500	-	-	-	-	NC4M-500	508	420	<b>1110</b>	<b>1530</b>	-	740

Size	Dimensions, inch										Weight, lb	
	Actuator	RA				Actuator	RE				RA	RE
		A	C	D	H		A	C	D	H		
2	NC4L-50	2.95	3.74	20.87	24.61	NC4M-50	4.88	3.58	<b>24.02</b>	<b>27.76</b>	78	89
2 1/2	NC4L-65	2.95	3.94	21.26	25.2	NC4M-65	5.71	3.82	<b>24.21</b>	<b>28.15</b>	84	93
3	NC4L-80	3.94	4.33	21.85	26.18	NC4M-80	6.5	4.25	<b>25.39</b>	<b>29.72</b>	89	100
4	NC4L-100	4.53	4.72	22.24	26.97	NC4M-100	7.64	4.72	<b>25.79</b>	<b>30.51</b>	93	111
6	NC4L-150	6.3	6.89	24.02	30.91	NC4M-150	9.02	6.85	<b>27.56</b>	<b>34.45</b>	131	160
8	NC4L-200	7.87	7.87	25.39	33.27	NC4M-200	9.57	7.91	<b>29.72</b>	<b>37.80</b>	184	291
10	NC4L-250	9.45	9.84	28.35	38.19	NC4M-250	11.69	9.88	<b>32.68</b>	<b>42.72</b>	256	347
12	NC4L-300	-	-	-	-	NC4M-300	13.31	10.59	<b>33.66</b>	<b>44.29</b>	-	489
14	NC4L-350	-	-	-	-	NC4M-350	15.75	12.24	<b>37.40</b>	<b>49.80</b>	-	667
16	NC4L-400	-	-	-	-	NC4M-400	15.75	13.9	<b>39.96</b>	<b>53.94</b>	-	844
20	NC4L-500	-	-	-	-	NC4M-500	20	16.54	<b>43.70</b>	<b>60.24</b>	-	1644

## HOW TO ORDER BASIS WEIGHT CONTROL UNIT nelesACE

### V-PORT SEGMENT VALVE RA AND RE FOR nelesACE

1.	2.	3.	4.	5.	6.	7.	8.
	RA		W	400	A	W	/
	RE	M	W	400	A	W	/

1. sign	CV-CODE FOR VALVE SIZE DN 25 (01")
	STANDARD CV
-	Without sign

2. sign	PRODUCT SERIES / DESIGN
RA	Wafer, reduced bore, Neles face-to-face length, Body PN50 / ANSI Class 300*
RE	Flanged, reduced bore, ISA S 75.04 and DIN/IEC 534 Part 3-2

\* Look table "5.sign", Column : "Max shut-off pressure".

3. sign	RA PRESSURE RATING	RE PRESSURE RATING
J	---	Body PN 10, flanged
K	---	Body PN 16, flanged
L	RA Body PN50 / ASME class 300 (no sign)	Body PN 25, flanged
M	---	Body PN 40, flanged
C	---	Body ANSI class 150, flanged
R	---	JIS 10K flanges
S	---	JIS 16K flanges
Y	Special, to be specified	

4. sign	CONSTRUCTION
W	Standard, drive shaft with keyway for nelesACE. Shaft/segment connection pinned and welded.
Y	Special, to be specified

5. sign	SIZE				
	Max shut-off pressure	DIN/ISO PN10	DIN/ISO PN16	DIN/ISO PN25	DIN/ISO PN40
050*	50 bar	equal to PN40	equal to PN40	equal to PN40	M
065*	50 bar	equal to PN16	K	equal to PN40	M
080*	50 bar	equal to PN40	equal to PN40	equal to PN40	M
100*	40 bar	equal to PN16	K	equal to PN40	M
150*	40 bar	equal to PN16	K	equal to PN40	M
200	35 bar	J	K	L	M
250	35 bar	J	K	L	M
300	30 bar	J	K	L	M
350	30 bar	J	K	L	M
400	30 bar	J	K	L	M
500	30 bar	J	K	L	M

\* According to DIN standard, flange dimensions in some sizes and pressure classes are same. That is reason why some sizes are available only some pressure classes.

6. sign	BODY	SEGMENT	SCREWS	SHAFT, PINS / BEARINGS
A	CF8M	Type AISI 329 + HCr	A2-70	Type AISI 329 / PTFE
C	CG8M	CG8M + HCr	B8M	XM-19 / PTFE

Seals for above:  
Gland packing: PTFE V-ring type  
Blind flange: PTFE

7. sign	SEAT MATERIAL AND CONSTRUCTION
W	Stainless steel + cobalt based hard facing Basis weight service

8. sign	FLANGE FACING
	<b>STANDARD</b>
-	ASME B16.5 (Ra 3.2 – 6.3 / RMS 125-250) Cover EN1092-1 Type B1

### STEP MOTOR ACTUATOR FOR nelesACE

1.	2.	3.
NC	4L	400

1. sign	PRODUCT GROUP
NC	Step motor actuator. Ambient temperature 0°C...+50°C/+32°F...+122°F, IP65 enclosure

2. sign	SERIES CODE
4L	Used with RA valve
4M	Used with RE valve

3. sign	ACCORDING TO THE SIZE OF THE SEGMENT VALVE
	Available for sizes: 050, 065, 080, 100, 150, 200, 250, 300, 350, 400, 500. Applicable only with RA... W and RE... W valves.

### CONTROL UNIT FOR nelesACE

1.	2.
ND4KS2	2

1. sign	CONTROL UNIT
ND4KS2	Control unit for pulse or time duration signals, includes push buttons for manual operations and IPCOMM software for serial communication protocol of the RS232 or RS485 interface. 1/2 step mode as a default. Position indication LCD. IP65 enclosure

2. sign	SUPPLY VOLTAGE
1	110 VAC
2	230 VAC

Subject to change without prior notice.

**Metso Automation Inc.**

**Europe**, Vanha Porvoontie 229, P.O. Box 304, FI-01301 VANTAA, Finland.  
Tel. +358 20 483 150. Fax +358 20 483 151

**North America**, 44 Bowditch Drive, P.O. Box 8044, Shrewsbury, MA 01545, USA.  
Tel. +1 508 852 0200. Fax +1 508 852 8172

**South America**, Av. Independência, 2500- Iporanga, 18087-101, Sorocaba-São Paulo, Brazil.  
Tel. +55 15 2102 9700. Fax +55 15 2102 9748/49

**Asia Pacific**, 20 Kallang Avenue, Lobby B, #06-00, PICO Creative Centre, Singapore 339411, Singapore.  
Tel. +65 6511 1011. Fax +65 6250 0830

**China**, 19/F, the Exchange Beijing, No. 118, Jianguo Lu Yi, Chaoyang Dist, 100022 Beijing, China.  
Tel. +86-10-6566-6600. Fax +86-10-6566-2575

**Middle East**, Roundabout 8, Unit AB-07, P.O. Box 17175, Jebel Ali Freezone, Dubai,  
United Arab Emirates. Tel. +971 4 883 6974. Fax +971 4 883 6836

[www.metso.com/valves](http://www.metso.com/valves)

