

# Reliable ESD valves in tower bottom lines in heavy oil units

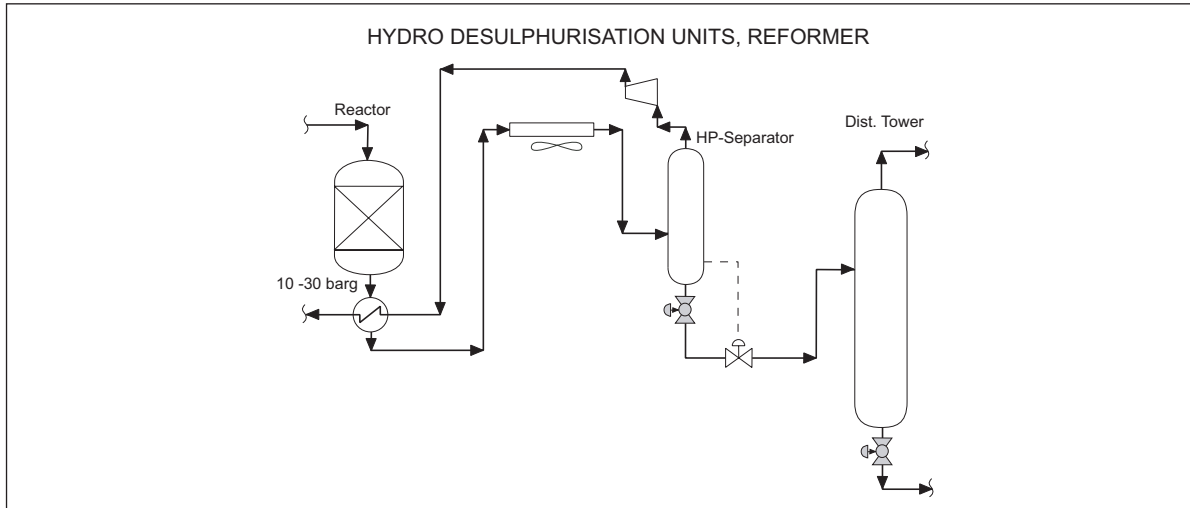

## Introduction

Besides fired heaters, the distillation tower bottom areas are the most fire-risky places in a refinery. When the question is of residual oils, high oil temperature, coke formation, sulphur corrosion and possible particles in the oil make the conditions even more severe.

Neles metal-seated ball valve with its constructional features and the Neles ValvGuard, partial stroke testing system, used to keep the valves under continuous watch are helping to minimize the fire risks in these areas.

## How Neles ValvGuard is applied in ESD valve controls

Neles ValvGuard can automatically partially close the valve to check its operation. The valve movement during the partial stroke testing can be set to 10% for example.

During the partial stroke test the cylinder pressure is measured. That information is used for the diagnostics information, i.e. valve breakaway pressure and load factor calculations. Operator will be notified automatically if pre-set alarm limits are exceeded.

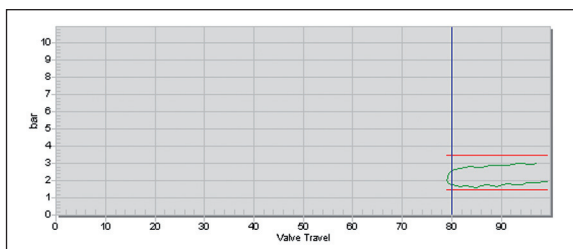

Refer to bulletins 9VG20 and 9VG20B for more information about Neles ValvGuard and its functionality.

In tower bottom lines the valve cannot be closed too much for testing because the pump may lose too much of its suction head.

However, e.g. a 10% rotation of the ball for testing does not take away of the head more than few mm, which is negligible compared to the total available head. The exact millimeters can be calculated for a given flow velocity in the bottom line based on the Cv values of the proposed valve solution.

## X Series Ball Valve with Spring-to-close Actuator and Neles ValvGuard



### VALVE SELECTION

#### Valve type - body style

Neles seat-supported ball valve series X is used in the sizes and pressures common in tower bottom lines in residual oil processing (sizes up to 6" (8") are common, for pressures refer to the diagram on first page).

The seat-supported MBV is available in the body versions:

- XA\_DWGAI2SJHADF, full bore
- XC\_DWGAI2SJHADF, reduced bore.

Reduced port ball valve is normally recommended for ESD service for smaller actuator size and better total economy.

The selection depends on the head loss analysis - how many millimeters is caused by the valve which should be compared to the available head.

#### Material options

Besides normal carbon steel (grade WCB) and stainless steel (grade SS316) the X series offering includes CromeMoly (ASTM gr. C5 or C12 on request).

#### Ball hard-facing options

Standard ball hard facing options often used for residual oils:

- Hard Cr-plating  
Economical. Not recommended over 300°C.
- CrC-carbide  
Used in temperatures over 300°C
- Nickel-boron based hard facings applied with spray and fuse method.  
Thick and hard layers for very erosive applications.

### ACTUATOR OPTIONS

#### Actuator sizing

Because of coke formation (over ~ 300°C ) a safety factor should be applied over normal torque requirements. Minimum factor 2 times over the normal torque with metal seats should be used.

#### Spring-to-close actuator

Neles offering includes large-enough actuator sizes for the highest required torques.

#### Double acting actuator with air volume tank and fail safe system

The cylinder size is essentially smaller than in the actuator with spring. Therefore this alternative may be preferred in spite of the additional air volume tank. Operation-wise it gives also a very safe closing.

Neles ValvGuard is not recommended to be used with double-acting actuators, since this solution always needs air operated valves. Air operated valve solution always need restrictor valves also, and those, if not set properly, may prevent valve to close.

#### Electric actuator with a gear

Can be used when specified. Needs fire protected motor and cables and probably a secured source of power supply.

Neles ValvGuard can not be used with electric actuators. Neles ValvGuard can be used with pneumatic actuators only.

#### Mechanical travel-stops for testing

In case the Neles ValvGuard is not used the mechanical stops in the actuator program can be used.

The offering includes locally insertible travel stops or pneumatic remotely operated jammers for preventing full closing of the valve during the tests.

### FIRE PROTECTION

Contact Metso Automation for standard fire safe boxes to keep the actuator operable in case of fire.

### OTHER VALVE OPTIONS IN NELES OFFERING

Consult with Metso Automation sales office for other options:

- Top-entry ball valve
- Possible to use welded valve connections and service the valve through the top-entry cover
- Used in very high pressures and in locations with extreme risks when pipe flanges can not be accepted
- Neldisc butterfly valve
- Very economical in large diameter – low pressure applications
- Available seat, bearing and body version combinations.

The information provided in this bulletin is advisory in nature, and is intended as a guideline only. For specific circumstances and more detailed information, please consult with your local automation expert at Metso.

#### Metso Automation Inc.

**Europe**, Vanha Porvoontie 229, P.O. Box 304, FI-01301 VANTAA, Finland.  
Tel. +358 20 483 150. Fax +358 20 483 151

**North America**, 44 Bowditch Drive, P.O. Box 8044, Shrewsbury, MA 01545, USA.  
Tel. +1 508 852 0200. Fax +1 508 852 8172

**South America**, Av. Independência, 2500- Iporanga, 18087-101, Sorocaba-São Paulo  
Brazil. Tel. +55 15 2102 9700. Fax +55 15 2102 9748/49

**Asia Pacific**, 20 Kallang Avenue, Lobby B, #06-00, PICO Creative Centre, Singapore 339411, Singapore.  
Tel. +65 6511 1011. Fax +65 6250 0830

**China**, 19/F, the Exchange Beijing, No. 118, Jianguo Lu Yi, Chaoyang Dist, 100022 Beijing, China.  
Tel. +86-10-6566-6600. Fax +86-10-6566-2575

**Middle East**, Roundabout 8, Unit AB-07, P.O. Box 17175, Jebel Ali Freezone, Dubai, United Arab Emirates. Tel. +971 4 883 6974. Fax +971 4 883 6836

[www.metso.com/valves](http://www.metso.com/valves)

